

DUX WATER HEATERS

HOT WATER SOLUTIONS PRODUCT GUIDE



BRANDS

NEW ZEALAND'S LEADING SUPPLIER OF
QUALITY PIPING & PLUMBING PRODUCTS.

AN ICONIC BRAND

An iconic brand since 1915, Dux is committed to producing high quality water heaters and to the on-going development of new products for the New Zealand market.

Dux water heaters are manufactured in a state-of-the-art facility using a Quality Endorsed Company production system. This ensures that customers have purchased the highest quality water heater available.

Dux is proudly owned by Noritz, an international hot water powerhouse and a leading Japanese manufacturer of residential and commercial water heaters.



Dux Manufacturing Facility



Akashi, Japan



BEFORE YOU MAKE A DECISION ABOUT WHICH HOT WATER SYSTEM IS RIGHT FOR YOUR HOME, THINK ABOUT:

- How much hot water you use daily
- Whether the size of your hot water system is sufficient for your household
- How much space you have
- Does your home have access to natural gas or LPG to heat your hot water
- How environmentally conscious you'd like to be
- Your budget
- Whether the system will be located inside or outside



proflo[®] for homes of all sizes

TOUGH BUT STYLISH HOT WATER SYSTEMS THAT WILL GO THE DISTANCE.

If you're looking to replace an existing electric storage water heater, Proflo is an ideal solution - available in a variety of cylinder sizes for homes of all sizes and delivering full mains pressure.



PROFLO 25L & 50L; SINGLE HANDED MODELS

- Proflo 50L boasts a compact 670mm height, making it an easier fit into tight cupboards
- Available as hardwired or plug-in models
- Low maintenance and long service life
- Full flow pressure to all outlets
- Can be installed indoors or out[#]
- Made in a Noritz manufacturing facility
- 7 years cylinder warranty, 1 year parts and labour*



PROFLO 135 - 300; SINGLE HANDED MODELS

- 490mm diameter; 135 & 180 cylinder sizes
- 580mm diameter; 180, 250 & 300 cylinder sizes
- Proflo water heaters boast a larger anode to increase cylinder life
- Internal heat trap
- Coated steel finish
- Side hot and cold plumbing connections
- Features durable Y class commercial grade enamel
- Hard-wearing, tough polymer base resists damage and is rust-proof
- Feature 50mm thick, dense foam insulation for less heat loss and lower running costs
- Screwless cylinder lids offer a cleaner appearance and are safer too
- Low maintenance and long service life
- Full flow pressure to all outlets
- Can be installed indoors or out[#]
- 10 years cylinder warranty, 1 year parts and labour*



SO MANY SIZES FOR HOT WATER
YOU CAN'T GO WRONG.



proflo[®] for homes of all sizes

TOUGH BUT STYLISH HOT WATER SYSTEMS THAT WILL GO THE DISTANCE.



PROFLO 80L - 400L; DUAL HANDED MODELS

- 80L - 400L Proflo water heaters boast a larger anode to increase cylinder life
- Dual handed plumbing connections
- Internal heat trap
- Coated steel finish
- Features durable Y class commercial grade enamel
- Hard-wearing, tough polymer base resists damage and is rust-proof
- Feature 50mm thick, dense foam insulation for less heat loss and lower running costs
- Water connections on both sides of the cylinder
- Screwless cylinder lids offer a cleaner appearance and are safer too
- Low maintenance and long service life
- Full flow pressure to all outlets
- Can be installed indoors or out#
- Twin element models available (315L and 400L only)
- 10 years cylinder warranty, 1 year parts and labour*



CAPACITY	NO. OF PEOPLE PER HOME
25L	-
50L	1
80L	1 - 2
125L	2 - 3
135L	2 - 3
160L	2 - 4
180L	2 - 4
250L	3 - 5
300	3 - 6
315L	4 - 6
400L	5 - 9

Adult icon can represent dishwasher or washing machine.
#Plug in models can only be installed indoors.

EXPANDED RANGE FOR
EVEN MORE CHOICE



gas continuous flow

INSTANT HOT WATER, HEATING WATER ONLY AS IT'S NEEDED.

Compact and efficient, Dux's latest range of Continuous Flow units are an excellent option for New Zealand homes. Dux gas continuous flow water heaters heat the water only as needed, not wasting energy by keeping water in a cylinder hot, earning it a 6 star (or higher) energy rating.

With several delivery options available, ensure you select a Dux continuous flow water heater that best suits to the number of outlets in the home.

NON-CONDENSING MODELS

- Available in 17L, 21L, and the new 26L/min model
- Up to 6.4 star equivalent energy efficiency[‡]
- The 26L model suits connection to water saving tapware
- 55°C factory set temperature
- Status display monitor on the 26L/min model
- Single copper heat exchanger for efficient heating
- Never runs out of hot water
- Superior technology straight from Noritz, a leading manufacturer of continuous flow water heaters
- Electronic ignition means no standby pilot light
- Natural gas and ULPG models
- Optional accessories include, temperature controllers, pipe covers, recess boxes, flue diverters and an anti-theft bracket
- 12 year warranty on heat exchanger, including 3 year parts and labour*



Our non-condensing range is available in three different capacities, ensuring there's a model to suit every family.

SIZING	MODELS		
	17L/min	21L/min	26L/min
No. of Outlets	2	2-3	3

IDEAL FOR RETROFITS

The 26L/min model features water and gas connections in identical locations to those found on current major competitor 26L models.

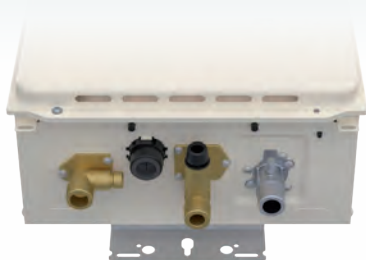

The top and bottom mounting brackets may also align with current key major competitor models to allow existing mounting points to be reused.

OPTIONAL ACCESSORIES



Accessories include separate controllers that allow you to select the hot water temperature you prefer – a welcome safety feature for families.



- Convenient 'Bath Fill' function
- Auto-stop water outlet volume (40L-650L)



- Convenient – select the temperature of your hot water.

HOT WATER ON DEMAND WHEN YOU NEED IT

[‡]17ENB models are rated 6.0 stars. 21ENB models are rated 6.1 stars. 26ENG models are rated 6.4 stars. 26ECB models are rated 6.7 stars. Relates to the equivalent star rating for the water heater.

gas continuous flow

INSTANT HOT WATER, HEATING WATER ONLY AS IT'S NEEDED.

CONDENSING MODEL

- Available in a 26L/min model
- Condensing models deliver over \$1000[#] savings over the 12 year warranted life of the heat exchanger
- Condensing continuous flow is a great option when connecting to ULPG bottled gas
- Smallest domestic condensing gas water heater
- 6.7 star equivalent energy efficiency[†]
- Dual heat exchanger design that boasts over 90% thermal efficiency by capturing additional heat
- Never runs out of hot water
- Features superior condensing technology that boasts over 90% thermal efficiency by capturing additional heat in the secondary heat exchanger
- Electronic ignition means no standby pilot light
- Natural gas and ULPG models
- Optional accessories include, temperature controllers, pipe covers, recess boxes, flue diverters and an anti-theft bracket
- 12 year warranty on heat exchanger, including 3 year parts and labour*



SAVES OVER
\$1000[#]



26L/MIN
CONDENSING MODEL

CONDENSING

Water is heated a second time using the heat from the exhaust gas, reducing wasted energy and lowering the exhaust temperature.

EXHAUST TEMPERATURE IS
ONLY 50°C

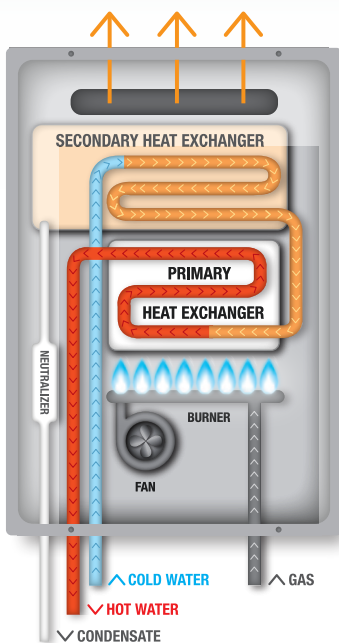

(Condensing technology)
Thermal efficiency = 90-96%

NON-CONDENSING

Water only passes through one heat exchanger and the energy from the exhaust gas is wasted.

EXHAUST TEMPERATURE IS
APPROX 200°C

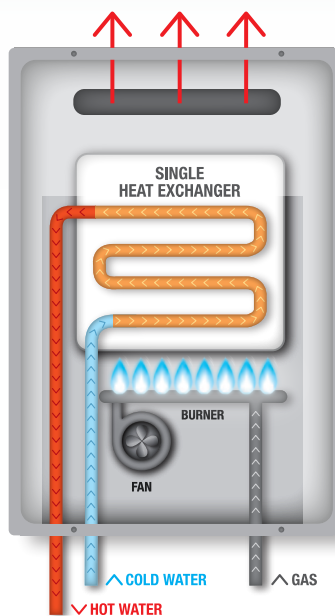

(Conventional technology)
Thermal efficiency = 80-84%

HIGHLY ENERGY EFFICIENT CONTINUOUS FLOW

[#]Running cost savings compared to a 4 star natural gas storage water heater over the 12 year warranty of the heat exchanger.

CONDENSING AND NON-CONDENSING ACCESSORIES

PIPE COVER



- Pipe covers conceal pipes and valves for a nice, tidy finish on the water heater.
- Pipe covers are supplied in the same colour as the continuous flow water heater
- Can be used with all Dux Always Hot continuous flow water heaters.

CF-H33-K450

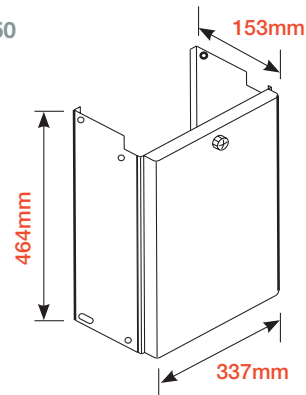

RECESS BOX



- Allows water heater to be installed recessed into the wall, providing a flush finish when installed
- Can be used with Dux Always Hot 26L continuous flow water heaters models only.

DUXRBOX26
suits 26ENA6L
and 26ENA6N

DUXRBOX26C
suits 26ECB6N
and 26ECB6L

DUXRBOX26G
suits 26ENG6N
and 26ENG6L

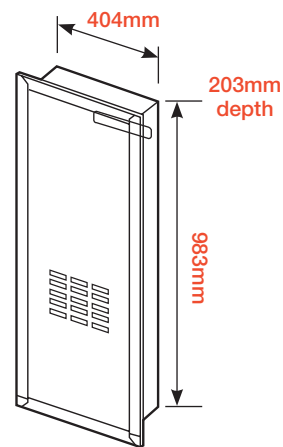

Note:
Dimensions above show the cut-out dimensions only.

ANTI THEFT BRACKET



- Secures your Dux Always Hot Water heater from theft
- A bracket fits over the water heaters pipes, preventing the unit from being removed from the wall without irreparable damage. Requires a Padlock (included).

H1224

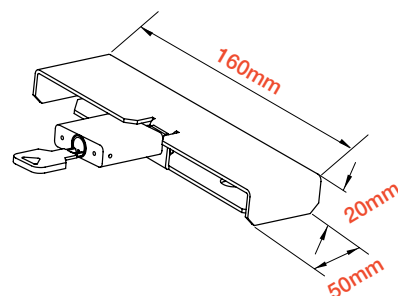

FLUE DIVERTERS



- Manufactured from durable stainless steel
- Designed to divert exhaust in a sideways direction away from windows, doors, fences, trees or other structures
- Allows the water heater to operate efficiently ensuring the exhaust is not being obstructed.

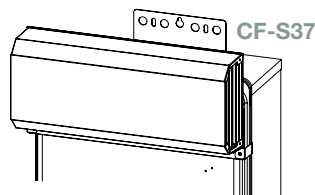

CF-L38

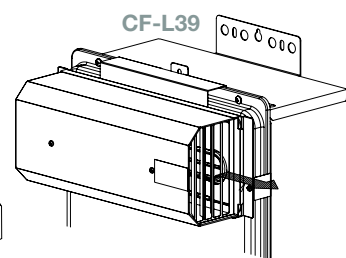
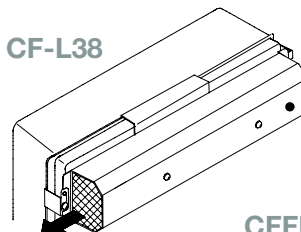

CFFD26S

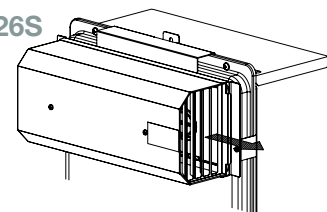

PART NO.	CONDENSING MODELS	NON-CONDENSING MODELS		
Model Number	26ECB	17ENB	21ENB	26ENG
Flue Diverter Part Number	CF-S37	CF-L39	CF-L38	CFFD26S

ALWAYS HOT GAS CONTINUOUS FLOW

MODELS	CONDENSING MODELS	NON-CONDENSING MODELS		
Model Number - preset 55°C	26ECB6N / 26ECB6L	17ENB6N / 17ENB6L	21ENB6N / 21ENB6L	26ENG6N / 26ENG6L
Flow Rate (l/min @ 25° rise)	26	17	21	26
Max Set Temperature °C	60	60	60	70
Min Operating Flow Rate (l/min)	2.4	2.4	2.4	2.4
Gas Consumption MJ/h - NG	175	126	159	195
Gas Consumption MJ/h - ULPG	185	127	159	195
Star Rating	6.7	6.0	6.1	6.4
Gas Type	NG or ULPG	NG or ULPG	NG or ULPG	NG or ULPG
Weight (kg)	18	14	15	16
Max water supply pressure (kPa)	1000	1000	1000	1000
Min water supply pressure (kPa)	200	200	200	200
Cold Water Connection	20mm ¾"	20mm ¾"	20mm ¾"	20mm ¾"
Hot Water Connection (mm)	20mm ¾"	20mm ¾"	20mm ¾"	20mm ¾"
Gas Connection (mm)	20mm ¾"	20mm ¾"	20mm ¾"	20mm ¾"

DIMENSIONS (MM)	CONDENSING MODEL	NON-CONDENSING MODELS			
Model	26L/min	17L/min	21L/min	26L/min	
A Width	350	350	350	350	
B Depth	170	170	170	170	
C Height - Unit	520	520	520	520	
D Height - Including Brackets	575	575	575	575	
E Hot Water Outlet (From Back)	45	40	40	40	
F Cold Water Inlet (From Back)	87	80	80	97	
G Gas Connection (From Back)	40	40	40	40	
Gas Connection Length (From Base)	50	50	50	49	
H Cold Connection Length (From Base)	48	48	48	48	
Hot Connection Length (From Base)	45	45	45	44	
I Drain Outlet (From Back)	21	N/A	N/A	N/A	
J Hot Water Outlet (From Centre)	138	131	131	131	
K Drain & Cold Water Outlet (From Centre)	63	24	24	54	
L Gas Connection (From Centre)	128	128	128	100	

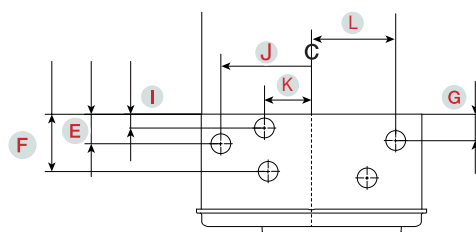
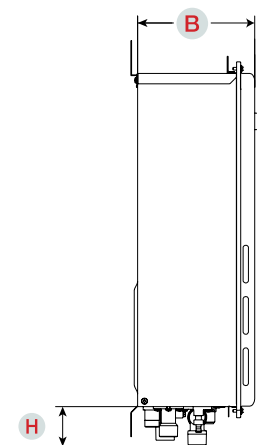
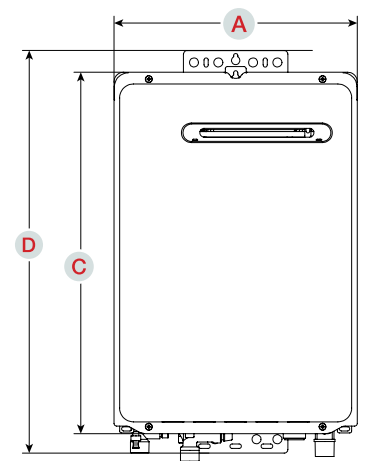

PROFLO® ELECTRIC STORAGE

SMALL ELECTRIC; SINGLE HANDED MODELS

SPECIFICATIONS	N25S124P [^]	N25S1	N50S124P [^]	N50S1
Storage Capacity (L)	30.5	30.5	48	48
Net Weight Empty (kg)	17	17	23	23
Element Sizes (kW)	2.4	3.6	2.4	3.6
Relief Valve Pressure (kPa)	1000	1000	1000	1000
Max Inlet Pressure (kPa)	800	800	800	800

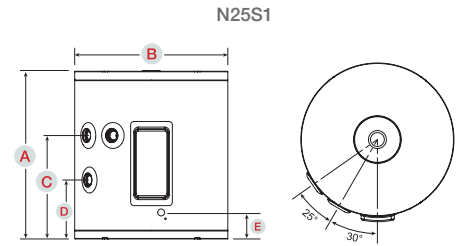

[^] Proflo Plug-in model (plugs into standard power point)

DIMENSIONS (MM)	25L	50L
A Overall Height	455	675
B Overall Diameter	405	405
C Hot Water Outlet	275	490
D Cold Water Inlet	145	155
E Electrical Entry	70	75

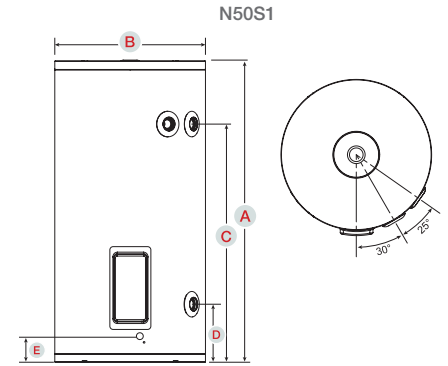

LARGE ELECTRIC; SINGLE HANDED MODELS

SPECIFICATIONS	N135T1	180TD1	180ST	N250T1	N300T1
Storage Capacity (L)	131	183.5	183.5	250	291
Element Sizes (kW)	1.8, 3.0	2.4, 3.0	2.4, 3.0	2.4, 3.0	2.4, 3.0
Net Weight Empty (kg)	50	65	60	77	94
Relief Valve Pressure (kPa)	1000	1000	1000	1000	1000
Max Inlet Pressure (kPa)	1120	1120	1120	1120	800

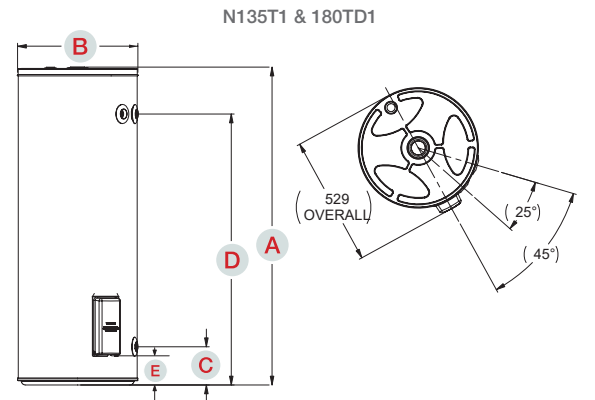

DIMENSIONS (MM)	N135T1	180TD1	180ST	N250T1	N300T1
A Overall Height	1298	1776	1190	1566	1804
B Overall Diameter	492	492	580	580	580
C Cold Water Inlet	156	156	196	196	196
D Hot Water Outlet	1106	1574	964	1342	1580
E Electrical Entry	85	100	100	100	100

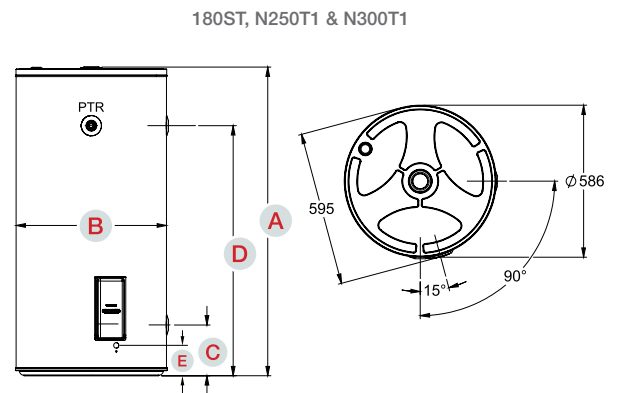

All Dux Proflo large electric water heaters are dual handed, except for N135T1, 180TD1, 180ST, N250T1 and N300T1 models and operate at 230 - 240V AC single phase electricity supply.

PROFLO® ELECTRIC STORAGE

LARGE ELECTRIC; DUAL HANDED MODELS

SPECIFICATIONS	80T1	125T1	160T1	250T1	315T1	315T2 TWIN ELEMENT	400T1	400T2 TWIN ELEMENT
Storage Capacity (L)	88	130	161	259	321	321	415	415
Hot Water Delivery Rating (L)	80	125	160	250	315	315	400	400
Twin Element Boost Capacity (L)	-	-	-	-	-	60	-	85
Element Sizes (kW)	1.8, 2.4, 3.6	1.8, 3.6	2.4, 3.6	3.6	3.6	2 x 3.6 or 2 x 4.8	3.6	2 x 3.6
Net Weight Empty (kg)	41	51	59	72	93	93	115	115
Relief Valve Pressure (kPa)	1400	1400	1400	1000	1000	1000	1000	1000
Max Inlet Pressure (kPa)	1120	1120	1120	800	800	800	800	800

DIMENSIONS (MM)	80T1	125T1	160T1	250T1	315T1 / 315T2	400T1 / 400T2
A Overall Height	925	1090	1315	1445	1765	1705
B Overall Diameter	490	530	530	620	620	705
C Cold Water Inlet	160	190	190	195	195	220
D Hot Water Outlet	735	865	1095	1210	1530	1445
E Electrical Entry	85	100	100	105	105	130

All Dux Proflo large electric water heaters are dual handed, except for N135T1, 180TD1, 180ST, N250T1 and N300T1 models and operate at 230 - 240V AC single phase electricity supply.

80L - 400L (DUAL HANDED MODELS)

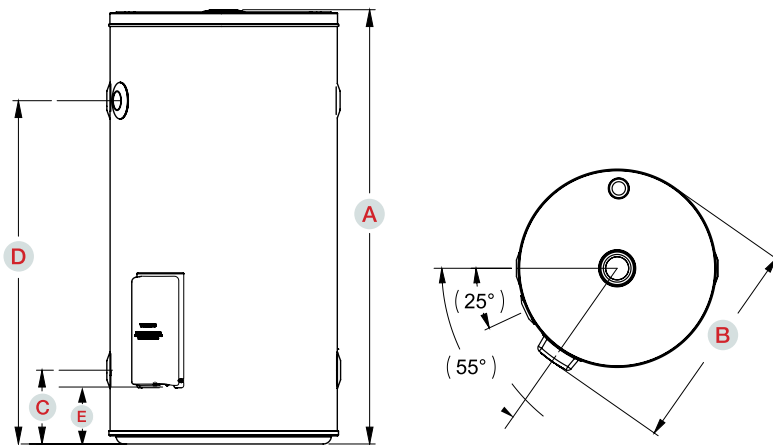



hotwater

duxhotwater.co.nz

*Full warranty terms and conditions are in the product's Owners Manual, visit www.spk.co.nz for full details and conditions which apply. © Dux Manufacturing Limited ABN 19 077 879 844. Lackey Rd, PO Box 209 Moss Vale, NSW 2577. The information supplied was correct at time of printing. Specification and materials may change without notice. © and ™ Trademarks of Dux Manufacturing Limited. JUN22



For hot water solutions call (09) 271 3720 or email sales@mmbrands.co.nz